

myISS

User Guide For PIC



Revision

Document Particulars

Title: myISS System User Guide	
Project: myISS	Prepared For: SIRIMIR (SIR)
Latest Version: 1.0	Status: Active

Revision History

Revision	Date	Author	Remarks
0.1	06/12/2023	MASLINA BINTI RAHMAT	



Contents

User Guide For PIC	2
1. Overview	5
2. Login & Logout myISS.....	8
3. Create ISS	12
14	
4. ISS Listing.....	15
16	
5. Report.....	17
User Guide For HOS.....	18
6. Login & Logout myISS.....	20
7. Approve ISS	24
26	
8. ISS Listing.....	27
28	
9. Report.....	29
User Guide For HOD	30
10. Login & Logout myISS.....	32
11. Approve ISS	36
38	
12. ISS Listing.....	39
40	
13. Report.....	41

1. Overview

This manual aims to enable SIRIM Industrial Research (SIRIMIR) staff who are involved with the ISS monthly reporting to effectively carry out the following tasks:

1. Monitor monthly ISS report via provided dashboard.
2. Identified fixed and additional core activities to suit the department business process.
3. Create new ISS, review, and approval of monthly approval.
4. Administrator to maintain the system.

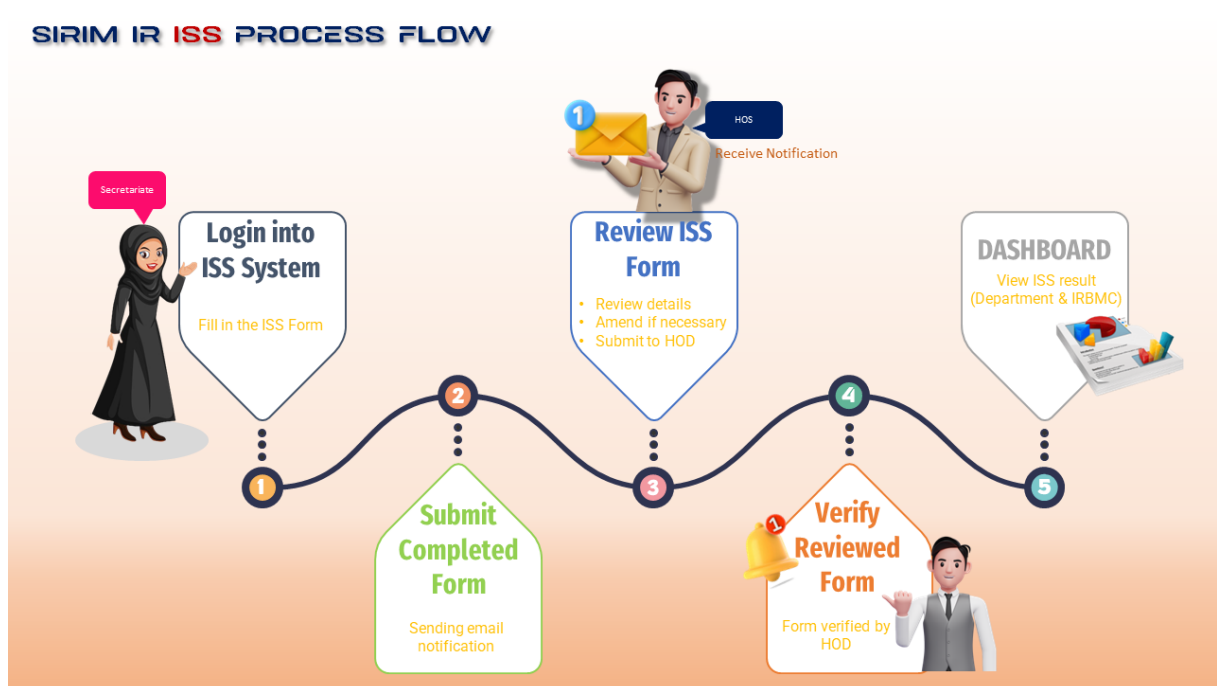

Diagram 1: Process flow involved in myISS

myISS consists of five (5) main modules:

1. Login and dashboard.
2. Create ISS.
3. Update ISS.
4. Report.
5. Administrator

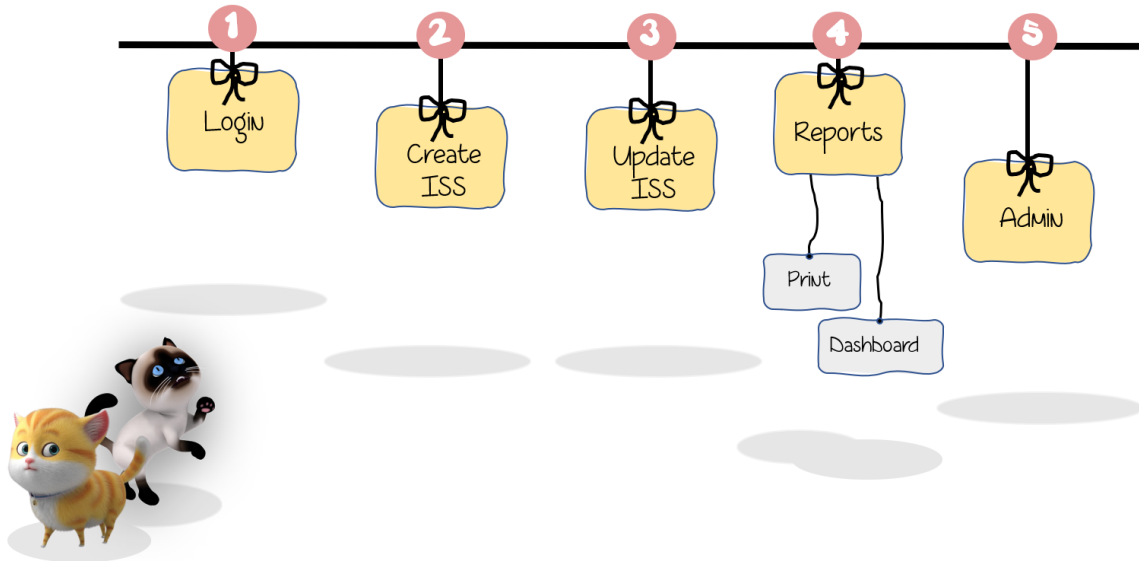

Diagram 2: Modules in myISS

3 roles involve in myISS, respectively:

1. Person In Charge (PIC)
2. Head of Section/Department (HOS/HOD)
3. System Administrator (IRMC)

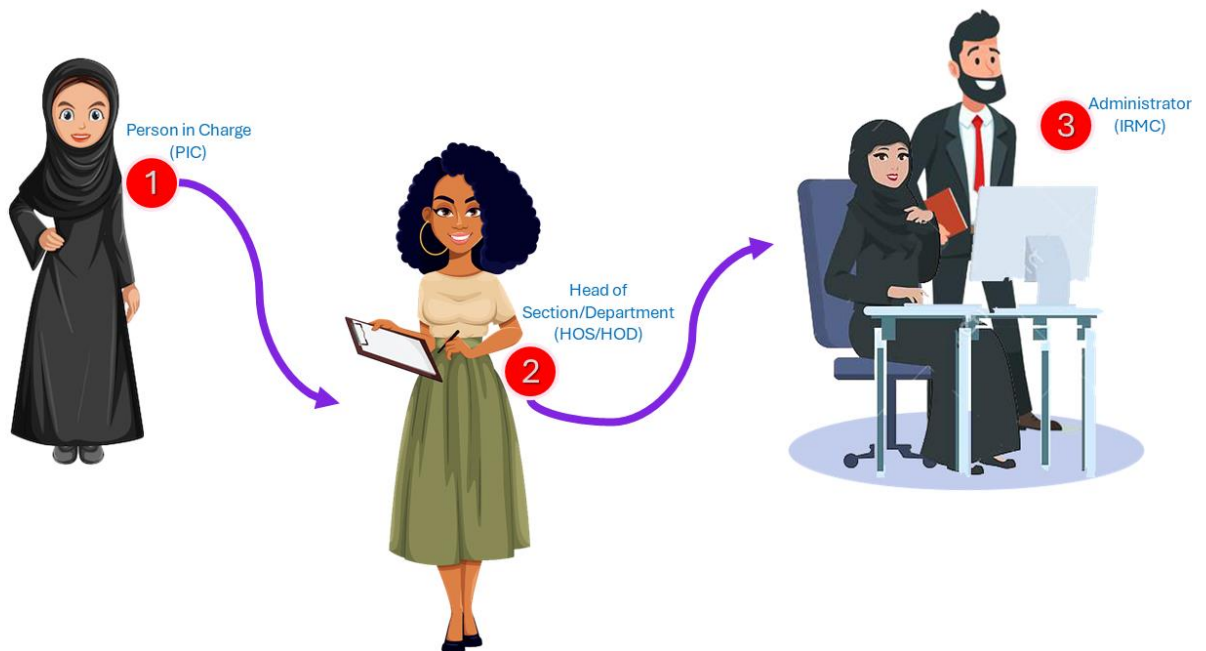

Diagram 3: Roles involves in the system



LOGIN AND DASHBOARD MODULE

2. Login & Logout myISS

To access the myISS, users should employ a modern web browser and enter the following *Uniform Resource Locator* (URL):

<https://myiss.sirim.my>.

This will lead users to the Login Page, depicted in Figure 1.

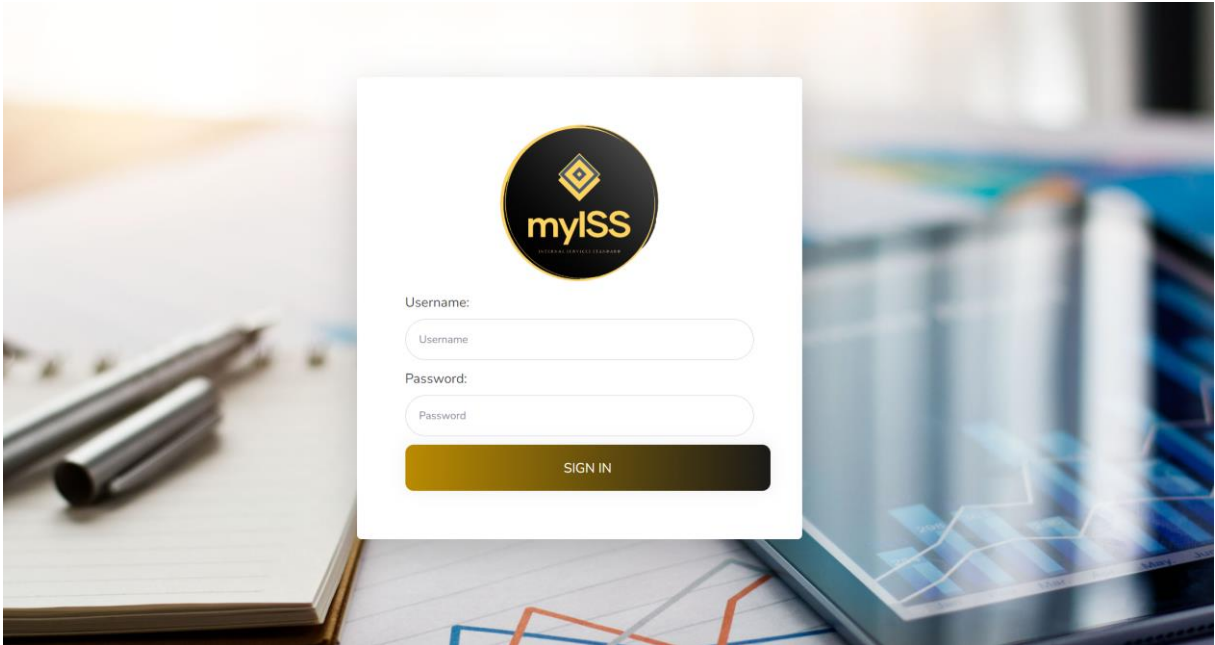

Figure 1: myISS Login Page

1. Key-in both username and password in the specified fields respectively.
**Note: Please verify that both inputs are accurate (be mindful of the Caps Lock).
2. Click the **SIGN IN** button. System will redirect users to the landing page which displays the dashboard as shown in Figure 2.

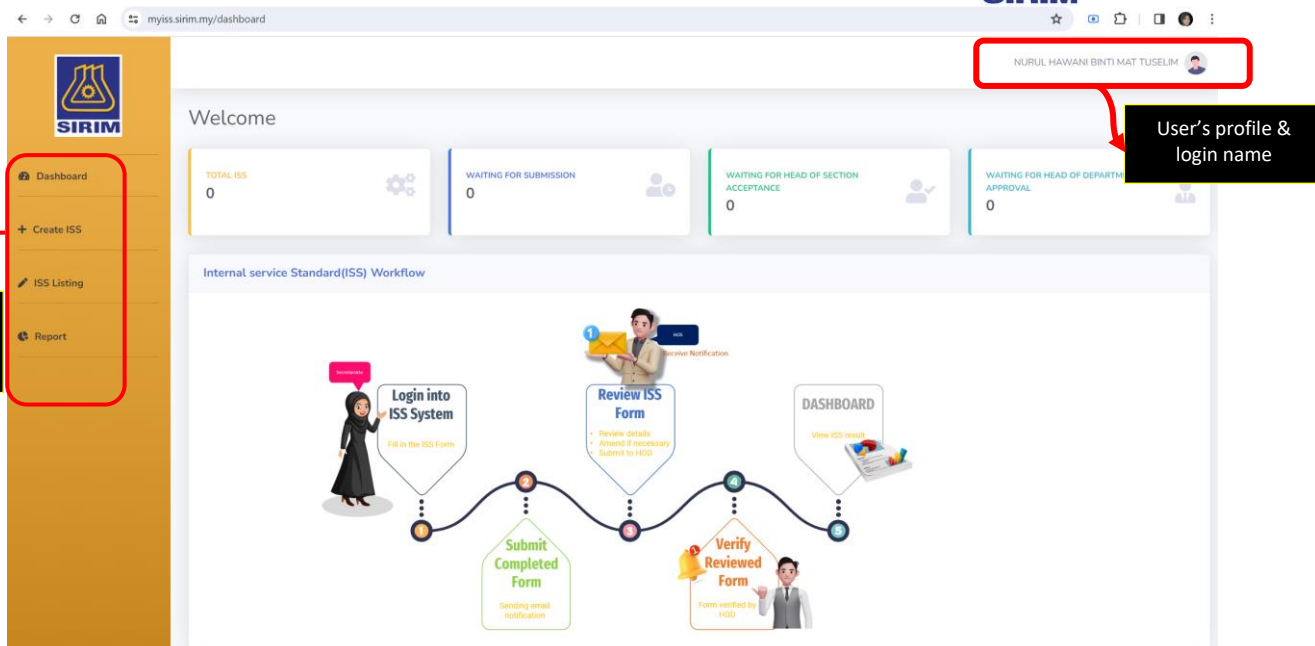



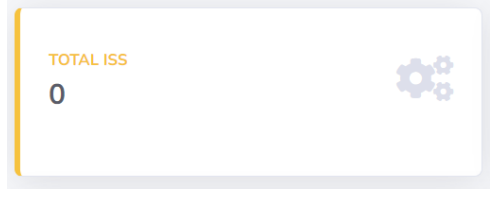
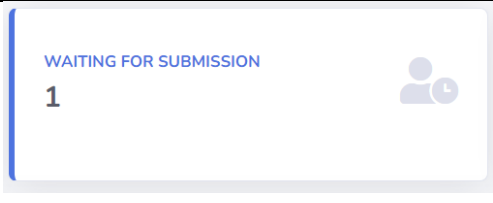
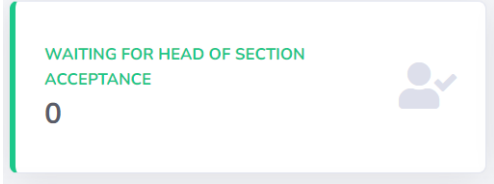
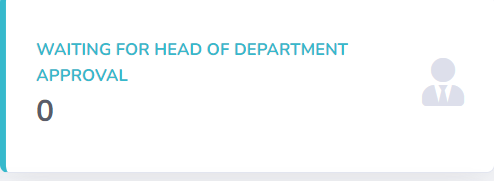

Figure 2: myISS Main Page Dashboard

NO	DESCRIPTION	FUNCTION
1	Left Navigation	Menu navigator
1.1	 Dashboard	Link to Dashboard page (home/landing page). <i>**Note: SIRIM Logo is also set to return to Dashboard page as home/landing page.</i>
1.2	 Create ISS	Link to create new myISS.
1.3	 ISS Listing	Link to view and manage myISS.
1.4	 Report	Link to report module.
2	Dashboard	Summary of activity.
2.1		Displays total number of approved ISS.
2.2		Displays number of "WAITING FOR SUBMISSION" where ISS with the status draft keyed-in by the user.

2.3		Displays number of "WAITING FOR HEAD OF SECTION ACCEPTANCE" where the ISS is to be reviewed and accepted by HOS.
2.4		Displays number of "WAITING FOR HEAD OF DEPARTMENT APPROVAL" where the ISS is to be reviewed and approved by HOD.

3. Your profile icon:

- On the top right of the screen click on the profile icon.

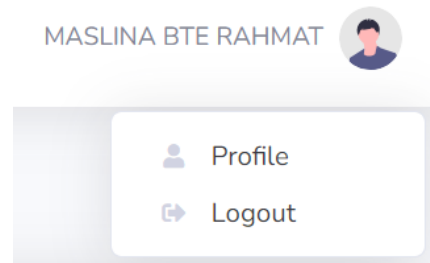

Figure 3: myISS profile and logout menu

3.1 Manage your profile.

3.1.1 Click on the "Profile" option.

3.1.2 The following profile form will be displayed as shown in Figure 4.

My Profile

Name: MASLINA BTE RAHMAT

Employee ID:

Email: maslina@sirim.my

Section: APPLICATION SYSTEM DEVELOPMENT SECTION
GROUP DIGITAL

Superior: NORAZAWATI BINTI MOHD. IHSAN

Figure 4: User Profile for reference.

3.2 Logout

3.2.1 Click on the "Logout" option.

3.2.2 The system will log you out and return to the login screen.

2

CREATE ISS MODULE

3. Create ISS

The purpose of this module is to create a new ISS for a particular month.

This module will enable users:

1. To create a new ISS for selected month in particular year.
2. To add core related activities.
3. To draft the ISS before submission.

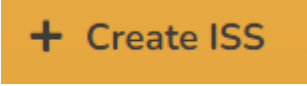
<p>STEP 1</p>	<p>In the left navigation menu, click the “+ Create ISS” icon.</p> <div style="text-align: center; margin: 10px 0;">  </div>
<p>STEP 2</p>	<p>New form for ISS creation</p> <ul style="list-style-type: none"> • The following form will be displayed. <div style="border: 1px solid #ccc; padding: 10px; margin: 10px 0;"> <p>Create Internal Service Standard</p> <p>Year: <input type="text" value="--- Pilih Tahun ---"/> Month: <input type="text" value="--- Pilih Bulan ---"/></p> <p>SBU/SUB: <input type="text" value="--- Choose ---"/> TC/C: <input type="text"/></p> <p>Core Process/Activity: <input style="width: 100%;" type="text"/></p> <p>Service Standard: <input style="width: 100%;" type="text"/></p> <p>Quantity(Completed): <input type="text" value="eg: N/A, etc..."/> Achievement(Meet ISS): <input type="text" value="eg: N/A, etc..."/> % Achievement: <input type="text"/></p> <p>Justification: <input style="width: 100%;" type="text"/></p> <p>Details of Corrective Action: <input style="width: 100%;" type="text"/></p> <p>Planned Date: <input type="text" value="dd/mm/yyyy"/> Completion Date: <input type="text" value="dd/mm/yyyy"/></p> <p>Remarks: <input style="width: 100%;" type="text"/></p> <p style="text-align: center;">Add More Core Process/Activity</p> </div> <ul style="list-style-type: none"> • Fill in the necessary input: <ul style="list-style-type: none"> ○ Select year from the drop-down “Year” combo box. ○ Select month from the drop-down “Month” combo box. ○ Core Process/Activity to be keyed-in by the PIC. ○ Service Standard is a date range identified based on departmental for a core process/activity respectively. For example, “2 working days”, “Within 3 working days after contract review approved” and “100% Completed as per schedule”. ○ Quantity (Completed) is the number of the target measurement for the core processes/activity. ○ Achievement (Meet ISS) is the actual completed for the core process/activity. ○ % Achievement is calculated automatically by the system. ○ For 100% achievement, fields of Justification, Details of Corrective Action,

Planned Date and Completion Date will be disabled. Otherwise, PIC shall keyed-in the input respectively.

- PIC is enabled to fill-in the remark if any.
- Upon new form completion, click “Add More Core Process/Activity” button.
- Pop-up message box will be displayed to notify the core process has been successfully added in the system.

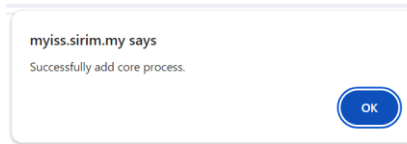

- Click “OK” button.
- The added core process/activity will be listed in the form with “DRAFT” status or “WAITING FOR SUBMISSION”.
- PIC can delete the core process respectively in this phase by clicking the “Delete” button.

No	Core Process/Activity	Service Standard	Quantity(Completed)	Achievement(Meet ISS)	% Achievement	Justification(for non-compliance)	Service Details of Corrective Actions Standard	Planned Date	Completion Date	Remarks	
1	Core Process 2	3 working days	2	2	100					All tasks are completed before the service standard 3 days	Delete

- Click “Add More Core Process/Activity” button to add more.
- Upon completion, click “Submit” button. The status will be changed to “AWAITING HOS APPROVAL”.

View submission status

- On the left navigation, click Dashboard menu.
- Note that your dashboard displays a new total of “WAITING FOR SUBMISSION”.

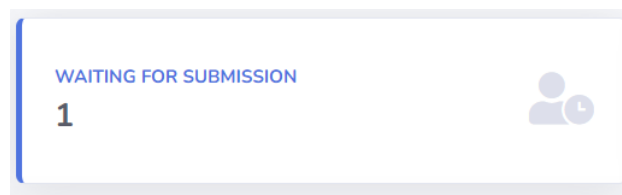

- For core process/activity which has been submitted, the number of “AWAITING HOS APPROVAL” tab will be updated.

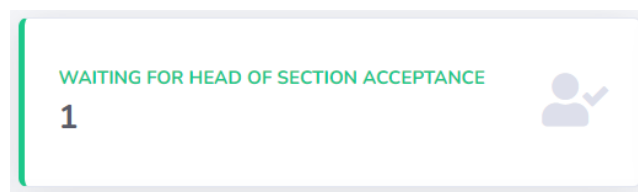



ISS LISTING MODULE

4. ISS Listing

The purpose of this module is to view the ISS that has been applied.
 This module will enable users:

1. To view all ISS applied with status respectively.
2. To track progress of ISS that has been applied.

STEP 1	<p>In the left navigation menu, click the “ISS Listing” menu.</p> <div style="text-align: center; margin-top: 20px;">  </div>																																																																																		
STEP 2	<p>List of ISS.</p> <ul style="list-style-type: none"> • The system will display all ISS that has been applied details as below: <div style="border: 1px solid #ccc; padding: 5px; margin-bottom: 10px;"> <p style="font-size: small; color: #4f81bd;">List of Internal Service Standard</p> <table border="1" style="width: 100%; border-collapse: collapse; font-size: x-small;"> <thead> <tr style="background-color: #333; color: white;"> <th></th> <th>Reference No</th> <th>Applicant Name</th> <th>Month</th> <th>Year</th> <th>Company</th> <th>Department</th> <th>Status</th> </tr> </thead> <tbody> <tr> <td style="text-align: center;">Select</td> <td>MY0715564986</td> <td>ASNIDA BINTI MOHD JAMALUDDIN</td> <td>February</td> <td>2023</td> <td>GROUP DIGITAL</td> <td>APPLICATION SYSTEM DEVELOPMENT SECTION</td> <td>AWAITING HOS APPROVAL</td> </tr> <tr> <td style="text-align: center;">Select</td> <td>MY0861833659</td> <td>ASNIDA BINTI MOHD JAMALUDDIN</td> <td>January</td> <td>2023</td> <td>GROUP DIGITAL</td> <td>APPLICATION SYSTEM DEVELOPMENT SECTION</td> <td>APPROVED</td> </tr> </tbody> </table> </div> <p>View iss in detail.</p> <ul style="list-style-type: none"> • Click “Select” button for the selected ISS. <div style="border: 1px solid #ccc; padding: 5px; margin-bottom: 10px;"> <table border="1" style="width: 100%; border-collapse: collapse; font-size: x-small;"> <thead> <tr style="background-color: #333; color: white;"> <th></th> <th>Reference No</th> <th>Applicant Name</th> <th>Month</th> <th>Year</th> <th>Company</th> <th>Department</th> <th>Status</th> </tr> </thead> <tbody> <tr> <td style="text-align: center;">Select</td> <td>MY0715564986</td> <td>ASNIDA BINTI MOHD JAMALUDDIN</td> <td>February</td> <td>2023</td> <td>GROUP DIGITAL</td> <td>APPLICATION SYSTEM DEVELOPMENT SECTION</td> <td>AWAITING HOS APPROVAL</td> </tr> </tbody> </table> </div> <ul style="list-style-type: none"> • The following details will be displayed as below: <div style="border: 1px solid #ccc; padding: 5px; margin-bottom: 10px;"> <p style="font-size: x-small; color: #4f81bd;">List of Internal Service Standard</p> <p style="font-size: x-small;">Month: February Year: 2023</p> <p style="font-size: x-small;">SBU/SUB: GROUP DIGITAL TC/I/C: APPLICATION SYSTEM DEVELOPMENT SECTION</p> <p style="font-size: x-small;">Status: AWAITING HOS APPROVAL</p> <table border="1" style="width: 100%; border-collapse: collapse; font-size: x-small;"> <thead> <tr style="background-color: #333; color: white;"> <th>No</th> <th>Core Process/Activity</th> <th>Service Standard</th> <th>Quantity(Completed)</th> <th>Achievement(Meet ISS)</th> <th>% Achievement</th> <th>Justification(for non-</th> </tr> </thead> <tbody> <tr> <td>1</td> <td>core 1</td> <td>1 working days</td> <td>2</td> <td>2</td> <td>100</td> <td></td> </tr> <tr> <td>2</td> <td>core 2</td> <td>3 working days</td> <td>3</td> <td>2</td> <td>67</td> <td></td> </tr> <tr> <td>3</td> <td>core 3</td> <td>2 working days</td> <td>2</td> <td>1</td> <td>50</td> <td></td> </tr> <tr> <td>4</td> <td>core 4</td> <td>N/A</td> <td>N/A</td> <td>N/A</td> <td>0</td> <td></td> </tr> <tr> <td colspan="5"></td> <td style="text-align: center;">Average</td> <td>72</td> </tr> </tbody> </table> <div style="border: 1px solid #ccc; padding: 5px; margin-top: 5px; font-size: x-small;"> <p>Prepared by: Name: ASNIDA BINTI MOHD JAMALUDDIN Designation: GROUP DIGITAL Date: 03 January 2024 Close</p> </div> </div> <ul style="list-style-type: none"> • Click “Close” button to go back to the ISS Listing page. 		Reference No	Applicant Name	Month	Year	Company	Department	Status	Select	MY0715564986	ASNIDA BINTI MOHD JAMALUDDIN	February	2023	GROUP DIGITAL	APPLICATION SYSTEM DEVELOPMENT SECTION	AWAITING HOS APPROVAL	Select	MY0861833659	ASNIDA BINTI MOHD JAMALUDDIN	January	2023	GROUP DIGITAL	APPLICATION SYSTEM DEVELOPMENT SECTION	APPROVED		Reference No	Applicant Name	Month	Year	Company	Department	Status	Select	MY0715564986	ASNIDA BINTI MOHD JAMALUDDIN	February	2023	GROUP DIGITAL	APPLICATION SYSTEM DEVELOPMENT SECTION	AWAITING HOS APPROVAL	No	Core Process/Activity	Service Standard	Quantity(Completed)	Achievement(Meet ISS)	% Achievement	Justification(for non-	1	core 1	1 working days	2	2	100		2	core 2	3 working days	3	2	67		3	core 3	2 working days	2	1	50		4	core 4	N/A	N/A	N/A	0							Average	72
	Reference No	Applicant Name	Month	Year	Company	Department	Status																																																																												
Select	MY0715564986	ASNIDA BINTI MOHD JAMALUDDIN	February	2023	GROUP DIGITAL	APPLICATION SYSTEM DEVELOPMENT SECTION	AWAITING HOS APPROVAL																																																																												
Select	MY0861833659	ASNIDA BINTI MOHD JAMALUDDIN	January	2023	GROUP DIGITAL	APPLICATION SYSTEM DEVELOPMENT SECTION	APPROVED																																																																												
	Reference No	Applicant Name	Month	Year	Company	Department	Status																																																																												
Select	MY0715564986	ASNIDA BINTI MOHD JAMALUDDIN	February	2023	GROUP DIGITAL	APPLICATION SYSTEM DEVELOPMENT SECTION	AWAITING HOS APPROVAL																																																																												
No	Core Process/Activity	Service Standard	Quantity(Completed)	Achievement(Meet ISS)	% Achievement	Justification(for non-																																																																													
1	core 1	1 working days	2	2	100																																																																														
2	core 2	3 working days	3	2	67																																																																														
3	core 3	2 working days	2	1	50																																																																														
4	core 4	N/A	N/A	N/A	0																																																																														
					Average	72																																																																													



REPORT MODULE

5. Report

The purpose of this module is to enable users to view the report of all ISS application in the whole year.

STEP 1	In the left navigation menu, click the “Report” menu. <div style="text-align: center; margin-top: 10px;">  </div>																																																																																																																																															
STEP 2	<p>View report.</p> <ul style="list-style-type: none"> The system will list all the ISS applied by SBU/SUB in a year. <div style="border: 1px solid #ccc; padding: 10px; margin-bottom: 10px;"> <p>Reporting</p> <p>Filter:</p> <p>Year: <input type="text" value="2023"/></p> <p>SBU/SUB: <input type="text" value="All"/></p> <p>TC/IC: <input type="text" value="All"/></p> <table border="1" style="width: 100%; border-collapse: collapse; text-align: center;"> <thead> <tr style="background-color: #f2f2f2;"> <th>TC/IC</th> <th>January</th> <th>February</th> <th>March</th> <th>April</th> <th>May</th> <th>June</th> <th>July</th> <th>August</th> <th>September</th> <th>October</th> <th>November</th> <th>December</th> </tr> </thead> <tbody> <tr><td>PRESIDENT AND GROUP CHIEF EXECUTIVE</td><td>0</td><td>0</td><td>0</td><td>0</td><td>0</td><td>0</td><td>0</td><td>0</td><td>0</td><td>0</td><td>0</td><td>0</td></tr> <tr><td>GROUP INTERNAL AUDIT</td><td>0</td><td>0</td><td>0</td><td>0</td><td>0</td><td>0</td><td>0</td><td>0</td><td>0</td><td>0</td><td>0</td><td>0</td></tr> <tr><td>GROUP CHIEF STRATEGY OFFICE</td><td>0</td><td>0</td><td>0</td><td>0</td><td>0</td><td>0</td><td>0</td><td>0</td><td>0</td><td>0</td><td>0</td><td>0</td></tr> <tr><td>GROUP CHIEF FINANCE OFFICE</td><td>0</td><td>0</td><td>0</td><td>0</td><td>0</td><td>0</td><td>0</td><td>0</td><td>0</td><td>0</td><td>0</td><td>0</td></tr> <tr><td>GROUP CHIEF PEOPLE & CULTURE OFFICE</td><td>0</td><td>0</td><td>0</td><td>0</td><td>0</td><td>0</td><td>0</td><td>0</td><td>0</td><td>0</td><td>0</td><td>0</td></tr> <tr><td>PERFORMANCE, REWARDS & PLANNING SECTION</td><td>0</td><td>0</td><td>0</td><td>0</td><td>0</td><td>0</td><td>0</td><td>0</td><td>0</td><td>0</td><td>0</td><td>0</td></tr> <tr><td>TALENT DEVELOPMENT & LEADERSHIP SECTION</td><td>0</td><td>0</td><td>0</td><td>0</td><td>0</td><td>0</td><td>0</td><td>0</td><td>0</td><td>0</td><td>0</td><td>0</td></tr> <tr><td>ENGAGEMENT, CULTURE & INDUSTRIAL RELATIONS SECTION</td><td>0</td><td>0</td><td>0</td><td>0</td><td>0</td><td>0</td><td>0</td><td>0</td><td>0</td><td>0</td><td>0</td><td>0</td></tr> <tr><td>GROUP CHIEF FUTURE OFFICE</td><td>0</td><td>0</td><td>0</td><td>0</td><td>0</td><td>0</td><td>0</td><td>0</td><td>0</td><td>0</td><td>0</td><td>0</td></tr> <tr><td>APPLICATION SYSTEM DEVELOPMENT SECTION</td><td>118</td><td>0</td><td>0</td><td>0</td><td>0</td><td>0</td><td>0</td><td>0</td><td>0</td><td>0</td><td>0</td><td>0</td></tr> </tbody> </table> <p style="text-align: center;">1 2 3 4 5 6 7 8 9 10 ...</p> </div> <p>Filter ISS list.</p> <ul style="list-style-type: none"> To filter by year of application, select necessary year from the “Year” drop down. <div style="margin-top: 5px;">Year: <input type="text" value="2023"/></div> To filter by SBU/SUB of application, select necessary SBU/SUB from the “SBU/SUB”. <div style="margin-top: 5px;">SBU/SUB: <input type="text" value="All"/></div> <ul style="list-style-type: none"> To filter by TC/IC of application, select necessary TC/IC from the “TC/IC”. <div style="margin-top: 5px;">TC/IC: <input type="text" value="All"/></div>	TC/IC	January	February	March	April	May	June	July	August	September	October	November	December	PRESIDENT AND GROUP CHIEF EXECUTIVE	0	0	0	0	0	0	0	0	0	0	0	0	GROUP INTERNAL AUDIT	0	0	0	0	0	0	0	0	0	0	0	0	GROUP CHIEF STRATEGY OFFICE	0	0	0	0	0	0	0	0	0	0	0	0	GROUP CHIEF FINANCE OFFICE	0	0	0	0	0	0	0	0	0	0	0	0	GROUP CHIEF PEOPLE & CULTURE OFFICE	0	0	0	0	0	0	0	0	0	0	0	0	PERFORMANCE, REWARDS & PLANNING SECTION	0	0	0	0	0	0	0	0	0	0	0	0	TALENT DEVELOPMENT & LEADERSHIP SECTION	0	0	0	0	0	0	0	0	0	0	0	0	ENGAGEMENT, CULTURE & INDUSTRIAL RELATIONS SECTION	0	0	0	0	0	0	0	0	0	0	0	0	GROUP CHIEF FUTURE OFFICE	0	0	0	0	0	0	0	0	0	0	0	0	APPLICATION SYSTEM DEVELOPMENT SECTION	118	0	0	0	0	0	0	0	0	0	0	0
TC/IC	January	February	March	April	May	June	July	August	September	October	November	December																																																																																																																																				
PRESIDENT AND GROUP CHIEF EXECUTIVE	0	0	0	0	0	0	0	0	0	0	0	0																																																																																																																																				
GROUP INTERNAL AUDIT	0	0	0	0	0	0	0	0	0	0	0	0																																																																																																																																				
GROUP CHIEF STRATEGY OFFICE	0	0	0	0	0	0	0	0	0	0	0	0																																																																																																																																				
GROUP CHIEF FINANCE OFFICE	0	0	0	0	0	0	0	0	0	0	0	0																																																																																																																																				
GROUP CHIEF PEOPLE & CULTURE OFFICE	0	0	0	0	0	0	0	0	0	0	0	0																																																																																																																																				
PERFORMANCE, REWARDS & PLANNING SECTION	0	0	0	0	0	0	0	0	0	0	0	0																																																																																																																																				
TALENT DEVELOPMENT & LEADERSHIP SECTION	0	0	0	0	0	0	0	0	0	0	0	0																																																																																																																																				
ENGAGEMENT, CULTURE & INDUSTRIAL RELATIONS SECTION	0	0	0	0	0	0	0	0	0	0	0	0																																																																																																																																				
GROUP CHIEF FUTURE OFFICE	0	0	0	0	0	0	0	0	0	0	0	0																																																																																																																																				
APPLICATION SYSTEM DEVELOPMENT SECTION	118	0	0	0	0	0	0	0	0	0	0	0																																																																																																																																				

--End of Document --



myISS

User Guide For HOS



LOGIN AND DASHBOARD MODULE

6. Login & Logout myISS

To access the myISS, users should employ a modern web browser and enter the following *Uniform Resource Locator* (URL):

<https://myiss.sirim.my>.

This will lead users to the Login Page, depicted in Figure 1.

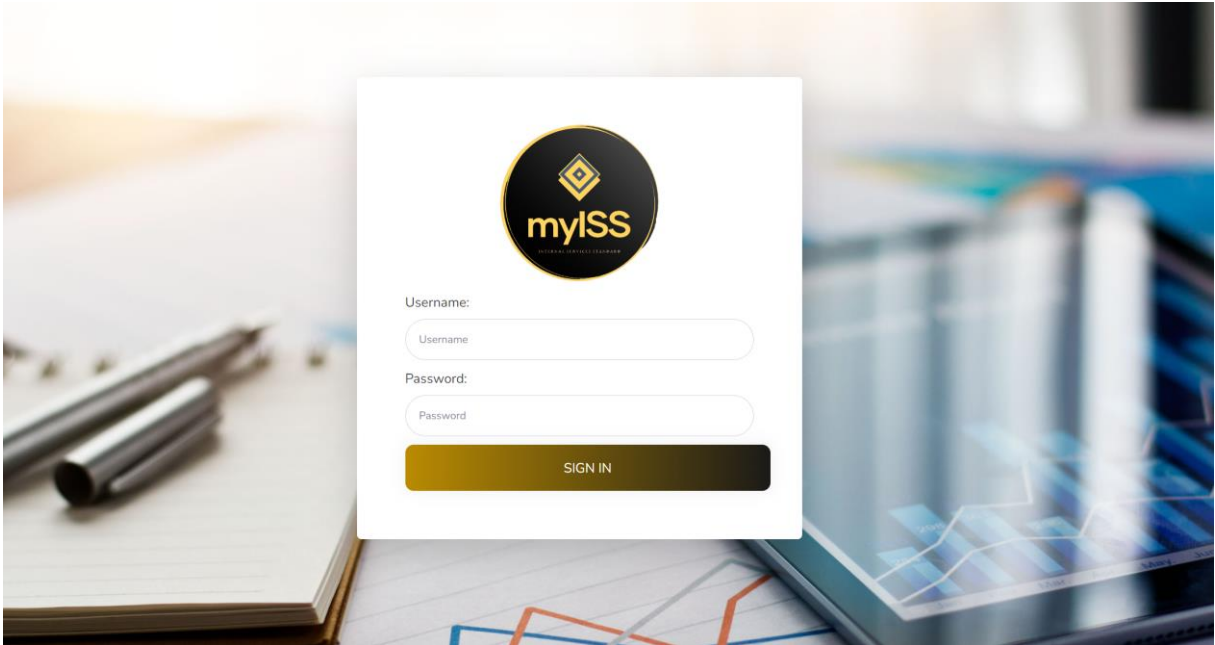

Figure 1: myISS Login Page

1. Key-in both username and password in the specified fields respectively.
**Note: Please verify that both inputs are accurate (be mindful of the Caps Lock).
2. Click the **SIGN IN** button. System will redirect users to the landing page which displays the dashboard as shown in Figure 2.

User's profile & login name

Left navigation menu

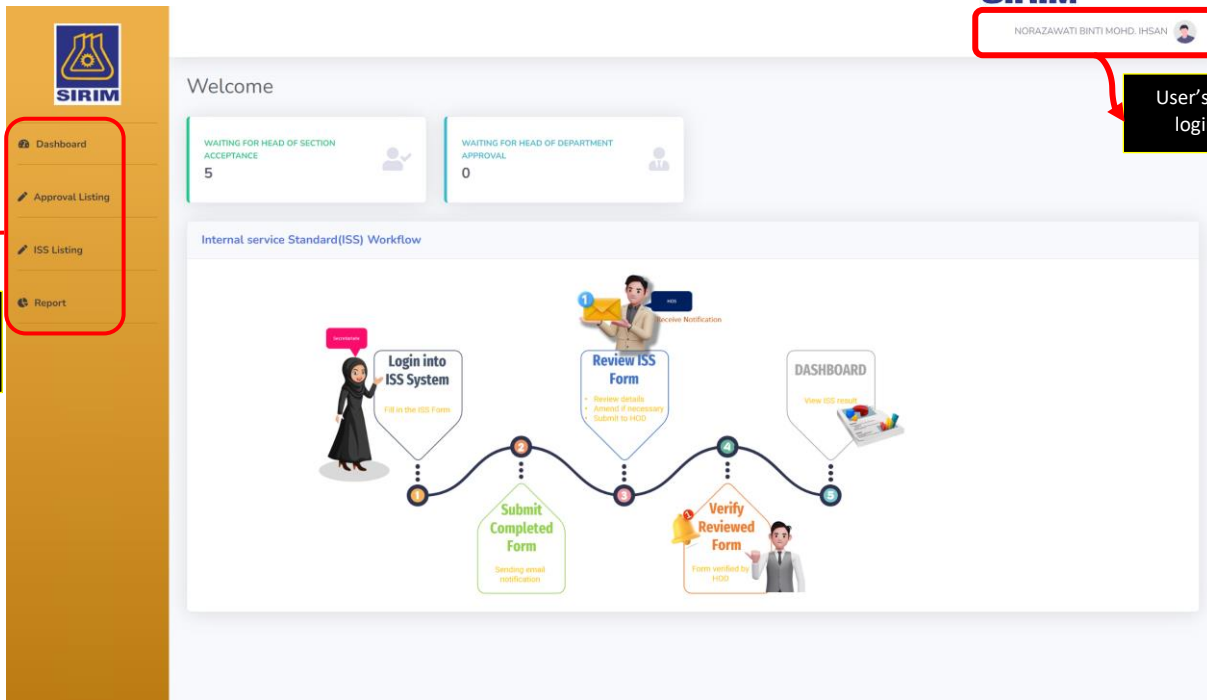



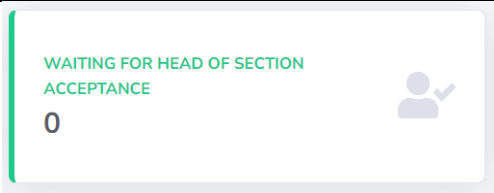
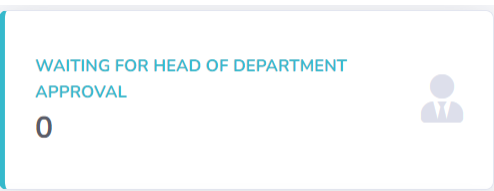

Figure 2: myISS Main Page Dashboard

NO	DESCRIPTION	FUNCTION
1	Left Navigation	Menu navigator
1.1	 Dashboard	Link to Dashboard page (home/landing page). <i>**Note: SIRIM Logo is also set to return to Dashboard page as home/landing page.</i>
1.2	 Approval Listing	Link to approve myISS.
1.3	 ISS Listing	Link to view myISS.
1.4	 Report	Link to report module.
2	Dashboard	Summary of activity.
2.1		Displays number of "WAITING FOR HEAD OF SECTION ACCEPTANCE" where the ISS is to be reviewed and accepted by HOS.
2.2		Displays number of "WAITING FOR HEAD OF DEPARTMENT APPROVAL" where the ISS is to be reviewed and approved by HOD.

3. Your profile icon:

- On the top right of the screen click on the profile icon.

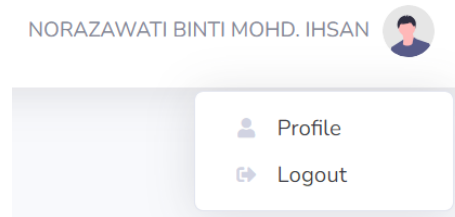

Figure 3: myISS profile and logout menu

3.1 Manage your profile.

3.1.1 Click on the “**Profile**” option.

3.1.2 The following profile form will be displayed as shown in Figure 4.

My Profile

Name:
NORAZAWATI BINTI MOHD. IHSAN

Employee ID:
2114

Email:
azawati@sirim.my

Section:
APPLICATION SYSTEM DEVELOPMENT SECTION
GROUP DIGITAL

Superior:
SABARINA BINTI HARUN

Figure 4: User Profile for reference.

3.2 Logout

3.2.1 Click on the “**Logout**” option.

3.2.2 The system will log you out and return to the login screen.

2

APPROVE ISS MODULE

7. Approve ISS

The purpose of this module is to approve a new ISS for a particular month. This module will enable users:

1. To approve or reject a new ISS for selected month in particular year.

STEP 1	In the left navigation menu, click the “Approval Listing” icon. <div style="text-align: center; margin: 10px 0;">  </div>																																																																																																	
STEP 2	<p>Approve a new ISS creation</p> <ul style="list-style-type: none"> The approval listing will be displayed as shown below. <div style="border: 1px solid #ccc; padding: 5px; margin-bottom: 10px;"> <p style="font-size: small; color: #4f81bd;">List of Waiting Approval</p> <table border="1" style="width: 100%; border-collapse: collapse; font-size: x-small;"> <thead> <tr style="background-color: #333; color: white;"> <th></th> <th>Reference No</th> <th>Month</th> <th>Year</th> <th>Company</th> <th>Department</th> <th>Status</th> <th>Requestor Name</th> </tr> </thead> <tbody> <tr> <td style="text-align: center;">Select</td> <td>MY0423332074</td> <td>November</td> <td>2023</td> <td>GROUP DIGITAL</td> <td>APPLICATION SYSTEM DEVELOPMENT SECTION</td> <td>AWAITING HOS APPROVAL</td> <td>MASLINA BTE RAHMAT</td> </tr> <tr> <td style="text-align: center;">Select</td> <td>MY0486388652</td> <td>February</td> <td>2023</td> <td>GROUP DIGITAL</td> <td>APPLICATION SYSTEM DEVELOPMENT SECTION</td> <td>AWAITING HOS APPROVAL</td> <td>NOR AMALINA BINTI MOHAMED FADZILAH</td> </tr> <tr> <td style="text-align: center;">Select</td> <td>MY0586022042</td> <td>March</td> <td>2023</td> <td>GROUP DIGITAL</td> <td>APPLICATION SYSTEM DEVELOPMENT SECTION</td> <td>AWAITING HOS APPROVAL</td> <td>NOR AMALINA BINTI MOHAMED FADZILAH</td> </tr> <tr> <td style="text-align: center;">Select</td> <td>MY0715564986</td> <td>February</td> <td>2023</td> <td>GROUP DIGITAL</td> <td>APPLICATION SYSTEM DEVELOPMENT SECTION</td> <td>AWAITING HOS APPROVAL</td> <td>ASNIDA BINTI MOHD JAMALUDDIN</td> </tr> <tr> <td style="text-align: center;">Select</td> <td>MY0760992972</td> <td>May</td> <td>2023</td> <td>GROUP DIGITAL</td> <td>APPLICATION SYSTEM DEVELOPMENT SECTION</td> <td>AWAITING HOS APPROVAL</td> <td>NOR AMALINA BINTI MOHAMED FADZILAH</td> </tr> </tbody> </table> </div> <ul style="list-style-type: none"> Click “Select” link to view the ISS in detail. <div style="border: 1px solid #ccc; padding: 5px; margin-bottom: 10px;"> <table border="1" style="width: 100%; border-collapse: collapse; font-size: x-small;"> <thead> <tr style="background-color: #333; color: white;"> <th></th> <th>Reference No</th> <th>Month</th> <th>Year</th> <th>Company</th> <th>Department</th> <th>Status</th> <th>Requestor Name</th> </tr> </thead> <tbody> <tr> <td style="text-align: center;">Select</td> <td>MY0423332074</td> <td>November</td> <td>2023</td> <td>GROUP DIGITAL</td> <td>APPLICATION SYSTEM DEVELOPMENT SECTION</td> <td>AWAITING HOS APPROVAL</td> <td>MASLINA BTE RAHMAT</td> </tr> </tbody> </table> </div> <ul style="list-style-type: none"> The following details will be displayed: <div style="border: 1px solid #ccc; padding: 5px; margin-bottom: 10px;"> <p style="font-size: x-small; color: #4f81bd;">List of Internal Service Standard</p> <p style="font-size: x-small;">Month: November Year: 2023</p> <p style="font-size: x-small;">SBU/SUB: GROUP DIGITAL TC/IC: APPLICATION SYSTEM DEVELOPMENT SECTION</p> <p style="font-size: x-small;">Status: AWAITING HOS APPROVAL</p> <table border="1" style="width: 100%; border-collapse: collapse; font-size: x-small;"> <thead> <tr style="background-color: #333; color: white;"> <th>No</th> <th>Core Process/Activity</th> <th>Service Standard</th> <th>Quantity(Completed)</th> <th>Achievement(Meet ISS)</th> <th>% Achievement</th> <th>Justification(for non-compliance)</th> <th>Service Details of Corrective Actions Standard</th> <th>Planned Date</th> <th>Completion Date</th> <th>Remarks</th> </tr> </thead> <tbody> <tr> <td style="text-align: center;">1</td> <td>Core Process 2</td> <td>3 working days</td> <td style="text-align: center;">2</td> <td style="text-align: center;">2</td> <td style="text-align: center;">100</td> <td></td> <td></td> <td></td> <td></td> <td style="font-size: xx-small;">All tasks are completed before the service standard 3 days</td> </tr> <tr> <td colspan="5"></td> <td style="text-align: center;">Average</td> <td style="text-align: center;">100</td> <td colspan="4"></td> </tr> </tbody> </table> <div style="font-size: x-small; margin-top: 5px;"> Prepared by: Name: MASLINA BTE RAHMAT Designation: GROUP DIGITAL Date: 03 January 2024 <div style="text-align: right; margin-top: 5px;"> Accept Reject Close </div> </div> </div> <ul style="list-style-type: none"> Upon approval completion, click “Accept” button to approve and fill in the message box. Click “Yes” button to proceed approval. 		Reference No	Month	Year	Company	Department	Status	Requestor Name	Select	MY0423332074	November	2023	GROUP DIGITAL	APPLICATION SYSTEM DEVELOPMENT SECTION	AWAITING HOS APPROVAL	MASLINA BTE RAHMAT	Select	MY0486388652	February	2023	GROUP DIGITAL	APPLICATION SYSTEM DEVELOPMENT SECTION	AWAITING HOS APPROVAL	NOR AMALINA BINTI MOHAMED FADZILAH	Select	MY0586022042	March	2023	GROUP DIGITAL	APPLICATION SYSTEM DEVELOPMENT SECTION	AWAITING HOS APPROVAL	NOR AMALINA BINTI MOHAMED FADZILAH	Select	MY0715564986	February	2023	GROUP DIGITAL	APPLICATION SYSTEM DEVELOPMENT SECTION	AWAITING HOS APPROVAL	ASNIDA BINTI MOHD JAMALUDDIN	Select	MY0760992972	May	2023	GROUP DIGITAL	APPLICATION SYSTEM DEVELOPMENT SECTION	AWAITING HOS APPROVAL	NOR AMALINA BINTI MOHAMED FADZILAH		Reference No	Month	Year	Company	Department	Status	Requestor Name	Select	MY0423332074	November	2023	GROUP DIGITAL	APPLICATION SYSTEM DEVELOPMENT SECTION	AWAITING HOS APPROVAL	MASLINA BTE RAHMAT	No	Core Process/Activity	Service Standard	Quantity(Completed)	Achievement(Meet ISS)	% Achievement	Justification(for non-compliance)	Service Details of Corrective Actions Standard	Planned Date	Completion Date	Remarks	1	Core Process 2	3 working days	2	2	100					All tasks are completed before the service standard 3 days						Average	100				
	Reference No	Month	Year	Company	Department	Status	Requestor Name																																																																																											
Select	MY0423332074	November	2023	GROUP DIGITAL	APPLICATION SYSTEM DEVELOPMENT SECTION	AWAITING HOS APPROVAL	MASLINA BTE RAHMAT																																																																																											
Select	MY0486388652	February	2023	GROUP DIGITAL	APPLICATION SYSTEM DEVELOPMENT SECTION	AWAITING HOS APPROVAL	NOR AMALINA BINTI MOHAMED FADZILAH																																																																																											
Select	MY0586022042	March	2023	GROUP DIGITAL	APPLICATION SYSTEM DEVELOPMENT SECTION	AWAITING HOS APPROVAL	NOR AMALINA BINTI MOHAMED FADZILAH																																																																																											
Select	MY0715564986	February	2023	GROUP DIGITAL	APPLICATION SYSTEM DEVELOPMENT SECTION	AWAITING HOS APPROVAL	ASNIDA BINTI MOHD JAMALUDDIN																																																																																											
Select	MY0760992972	May	2023	GROUP DIGITAL	APPLICATION SYSTEM DEVELOPMENT SECTION	AWAITING HOS APPROVAL	NOR AMALINA BINTI MOHAMED FADZILAH																																																																																											
	Reference No	Month	Year	Company	Department	Status	Requestor Name																																																																																											
Select	MY0423332074	November	2023	GROUP DIGITAL	APPLICATION SYSTEM DEVELOPMENT SECTION	AWAITING HOS APPROVAL	MASLINA BTE RAHMAT																																																																																											
No	Core Process/Activity	Service Standard	Quantity(Completed)	Achievement(Meet ISS)	% Achievement	Justification(for non-compliance)	Service Details of Corrective Actions Standard	Planned Date	Completion Date	Remarks																																																																																								
1	Core Process 2	3 working days	2	2	100					All tasks are completed before the service standard 3 days																																																																																								
					Average	100																																																																																												

- Click “Reject” button to reject and fill in the message box. Click “Yes” button to proceed.
- HOD will receive a notification if the ISS is approved by HOD. The following email will be displayed:

SIRIM ISS: Status Notification

 sirimapps@sirim.my
To: NOR AMALINA BINTI MOHAMED FADZILAH

Sat 6/1/2024 1:01 PM

SIRIM ISS - Approval Notification

Dear Sir/Madam SABARINA BINTI HARUN,

You have a new Internal Service Standard(ISS) available for your review, to approve in SIRIM ISS.

SIRIM ISS Reference number: MY0586022042
SIRIM ISS Creator Name: SABARINA BINTI HARUN
Month/year: March 2023
SBU/SUB: GROUP OPERATIONS
TC/IC: APPLICATION SYSTEM DEVELOPMENT SECTION

Please login [here](#) to approve.

Thank you.

- PIC will receive a notification if the ISS is rejected by HOS. The following email will be displayed:

SIRIM ISS: Status Notification

 sirimapps@sirim.my
To: NOR AMALINA BINTI MOHAMED FADZILAH

Sat 6/1/2024 12:56 PM

SIRIM ISS - Approval Notification

Dear Sir/Madam NOR AMALINA BINTI MOHAMED FADZILAH,

This is to inform that your Internal Service Standard(ISS) available in SIRIM ISS has been rejected.

SIRIM ISS Reference number: MY0486388652
SIRIM ISS Creator Name: NOR AMALINA BINTI MOHAMED FADZILAH
Month/year: February 2023
SBU/SUB: GROUP DIGITAL
TC/IC: APPLICATION SYSTEM DEVELOPMENT SECTION
Reason: testing

Please login [here](#) to review.

Thank you.

View submission status

- On the left navigation, click Dashboard menu.
- Note that your dashboard displays a new total of “WAITING FOR HEAD OF ACCEPTANCE”.

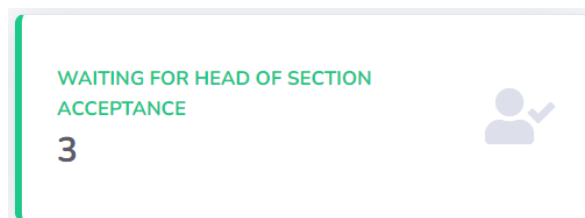

WAITING FOR HEAD OF SECTION
ACCEPTANCE

3

- For core process/activity which has been approved, the number of “AWAITING HOD APPROVAL” tab will be updated in the dashboard.

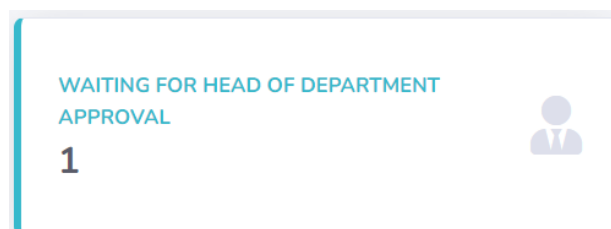

WAITING FOR HEAD OF DEPARTMENT
APPROVAL

1



ISS LISTING MODULE

8. ISS Listing

The purpose of this module is to view the ISS that has been applied by PIC.

This module will enable users:

- 3 To view all ISS applied with status respectively.
- 4 To track progress of ISS that has been applied.

STEP 1	<p>In the left navigation menu, click the “ISS Listing” menu.</p> <div style="text-align: center; margin-top: 20px;">  </div>																																																																																																																																				
STEP 2	<p>List of ISS.</p> <ul style="list-style-type: none"> The system will display all ISS that has been applied details as below: <div style="margin-top: 10px;"> <p>List of ISS</p> <table border="1" style="width: 100%; border-collapse: collapse; text-align: center;"> <thead> <tr style="background-color: #333; color: white;"> <th></th> <th>Reference No</th> <th>Applicant Name</th> <th>Company</th> <th>Department</th> <th>Month</th> <th>Year</th> <th>Average % Achievement</th> <th>Status</th> </tr> </thead> <tbody> <tr> <td>Select</td> <td>MY0547607653</td> <td>NOR AMALINA BINTI MOHAMED FADZILAH</td> <td>GROUP DIGITAL</td> <td>APPLICATION SYSTEM DEVELOPMENT SECTION</td> <td>January</td> <td>2023</td> <td>118</td> <td>APPROVED</td> </tr> <tr> <td>Select</td> <td>MY0586022042</td> <td>NOR AMALINA BINTI MOHAMED FADZILAH</td> <td>GROUP DIGITAL</td> <td>APPLICATION SYSTEM DEVELOPMENT SECTION</td> <td>March</td> <td>2023</td> <td>100</td> <td>AWAITING HOD APPROVAL</td> </tr> <tr> <td>Select</td> <td>MY0861833659</td> <td>ASNIDA BINTI MOHD JAMALUDDIN</td> <td>GROUP DIGITAL</td> <td>APPLICATION SYSTEM DEVELOPMENT SECTION</td> <td>January</td> <td>2023</td> <td>95</td> <td>APPROVED</td> </tr> </tbody> </table> </div> <p>View iss in detail.</p> <ul style="list-style-type: none"> Click “Select” button for the selected ISS. <div style="margin-top: 10px;"> <table border="1" style="width: 100%; border-collapse: collapse; text-align: center;"> <thead> <tr style="background-color: #333; color: white;"> <th></th> <th>Reference No</th> <th>Applicant Name</th> <th>Company</th> <th>Department</th> <th>Month</th> <th>Year</th> <th>Average % Achievement</th> <th>Status</th> </tr> </thead> <tbody> <tr> <td>Select</td> <td>MY0547607653</td> <td>NOR AMALINA BINTI MOHAMED FADZILAH</td> <td>GROUP DIGITAL</td> <td>APPLICATION SYSTEM DEVELOPMENT SECTION</td> <td>January</td> <td>2023</td> <td>118</td> <td>APPROVED</td> </tr> </tbody> </table> </div> <ul style="list-style-type: none"> The following details will be displayed as below: <div style="margin-top: 10px;"> <p>List of Internal Service Standard</p> <p>Month: January Year: 2023</p> <p>SBU/SUB: GROUP DIGITAL TC/C: APPLICATION SYSTEM DEVELOPMENT SECTION</p> <p>Status: APPROVED</p> <table border="1" style="width: 100%; border-collapse: collapse; text-align: center;"> <thead> <tr style="background-color: #333; color: white;"> <th>No</th> <th>Core Process/Activity</th> <th>Service Standard</th> <th>Quantity(Completed)</th> <th>Achievement(Meet ISS)</th> <th>% Achievement</th> <th>Justification(for non-compliance)</th> <th>Service Details of Corrective Actions Standard</th> <th>Planned Date</th> <th>Completion Date</th> <th>Remarks</th> </tr> </thead> <tbody> <tr> <td>1</td> <td>core 1</td> <td>1 working days</td> <td>1</td> <td>1</td> <td>100</td> <td></td> <td></td> <td></td> <td></td> <td></td> </tr> <tr> <td>2</td> <td>core 2</td> <td>3 working days</td> <td>5</td> <td>4</td> <td>80</td> <td>tak cukup masa</td> <td>try to settle by the end of this month</td> <td>27/9/2023</td> <td>30/9/2023</td> <td></td> </tr> <tr> <td>3</td> <td>core 3</td> <td>N/A</td> <td>N/A</td> <td>N/A</td> <td>0</td> <td></td> <td></td> <td></td> <td></td> <td></td> </tr> <tr> <td>4</td> <td>core 4</td> <td>1 working days</td> <td>1</td> <td>2</td> <td>100</td> <td></td> <td></td> <td></td> <td></td> <td></td> </tr> <tr> <td>5</td> <td>core 5</td> <td>5 working days</td> <td>6</td> <td>6</td> <td>100</td> <td></td> <td></td> <td></td> <td></td> <td></td> </tr> <tr> <td colspan="5"></td> <td>Average</td> <td>95</td> <td colspan="5"></td> </tr> </tbody> </table> <div style="margin-top: 10px; background-color: #f0f0f0; padding: 5px;"> <p>Prepared by: Name: NOR AMALINA BINTI MOHAMED FADZILAH Designation: GROUP DIGITAL Date: 23 October 2023</p> <div style="text-align: right;"> Close </div> </div> </div> <ul style="list-style-type: none"> Click “Close” button to go back to the ISS Listing page. 		Reference No	Applicant Name	Company	Department	Month	Year	Average % Achievement	Status	Select	MY0547607653	NOR AMALINA BINTI MOHAMED FADZILAH	GROUP DIGITAL	APPLICATION SYSTEM DEVELOPMENT SECTION	January	2023	118	APPROVED	Select	MY0586022042	NOR AMALINA BINTI MOHAMED FADZILAH	GROUP DIGITAL	APPLICATION SYSTEM DEVELOPMENT SECTION	March	2023	100	AWAITING HOD APPROVAL	Select	MY0861833659	ASNIDA BINTI MOHD JAMALUDDIN	GROUP DIGITAL	APPLICATION SYSTEM DEVELOPMENT SECTION	January	2023	95	APPROVED		Reference No	Applicant Name	Company	Department	Month	Year	Average % Achievement	Status	Select	MY0547607653	NOR AMALINA BINTI MOHAMED FADZILAH	GROUP DIGITAL	APPLICATION SYSTEM DEVELOPMENT SECTION	January	2023	118	APPROVED	No	Core Process/Activity	Service Standard	Quantity(Completed)	Achievement(Meet ISS)	% Achievement	Justification(for non-compliance)	Service Details of Corrective Actions Standard	Planned Date	Completion Date	Remarks	1	core 1	1 working days	1	1	100						2	core 2	3 working days	5	4	80	tak cukup masa	try to settle by the end of this month	27/9/2023	30/9/2023		3	core 3	N/A	N/A	N/A	0						4	core 4	1 working days	1	2	100						5	core 5	5 working days	6	6	100											Average	95					
	Reference No	Applicant Name	Company	Department	Month	Year	Average % Achievement	Status																																																																																																																													
Select	MY0547607653	NOR AMALINA BINTI MOHAMED FADZILAH	GROUP DIGITAL	APPLICATION SYSTEM DEVELOPMENT SECTION	January	2023	118	APPROVED																																																																																																																													
Select	MY0586022042	NOR AMALINA BINTI MOHAMED FADZILAH	GROUP DIGITAL	APPLICATION SYSTEM DEVELOPMENT SECTION	March	2023	100	AWAITING HOD APPROVAL																																																																																																																													
Select	MY0861833659	ASNIDA BINTI MOHD JAMALUDDIN	GROUP DIGITAL	APPLICATION SYSTEM DEVELOPMENT SECTION	January	2023	95	APPROVED																																																																																																																													
	Reference No	Applicant Name	Company	Department	Month	Year	Average % Achievement	Status																																																																																																																													
Select	MY0547607653	NOR AMALINA BINTI MOHAMED FADZILAH	GROUP DIGITAL	APPLICATION SYSTEM DEVELOPMENT SECTION	January	2023	118	APPROVED																																																																																																																													
No	Core Process/Activity	Service Standard	Quantity(Completed)	Achievement(Meet ISS)	% Achievement	Justification(for non-compliance)	Service Details of Corrective Actions Standard	Planned Date	Completion Date	Remarks																																																																																																																											
1	core 1	1 working days	1	1	100																																																																																																																																
2	core 2	3 working days	5	4	80	tak cukup masa	try to settle by the end of this month	27/9/2023	30/9/2023																																																																																																																												
3	core 3	N/A	N/A	N/A	0																																																																																																																																
4	core 4	1 working days	1	2	100																																																																																																																																
5	core 5	5 working days	6	6	100																																																																																																																																
					Average	95																																																																																																																															

4

REPORT MODULE

9. Report

The purpose of this module is to enable users to view the report of their ISS application in the whole year.

STEP 1	In the left navigation menu, click the “Report” menu. <div style="text-align: center; margin-top: 10px;">  </div>																																																																																																																																															
STEP 2	<p>View report.</p> <ul style="list-style-type: none"> The system will list all the ISS applied by TC/IC in a year. <div style="border: 1px solid #ccc; padding: 5px; margin-bottom: 10px;"> <p>Reporting</p> <p>Filter:</p> <p>Year: <input type="text" value="2023"/></p> <p>SBU/SUB: <input type="text" value="All"/></p> <p>TC/IC: <input type="text" value="All"/></p> </div> <table border="1" style="width: 100%; border-collapse: collapse; text-align: center;"> <thead> <tr style="background-color: #f2f2f2;"> <th>TC/IC</th> <th>January</th> <th>February</th> <th>March</th> <th>April</th> <th>May</th> <th>June</th> <th>July</th> <th>August</th> <th>September</th> <th>October</th> <th>November</th> <th>December</th> </tr> </thead> <tbody> <tr><td>PRESIDENT AND GROUP CHIEF EXECUTIVE</td><td>0</td><td>0</td><td>0</td><td>0</td><td>0</td><td>0</td><td>0</td><td>0</td><td>0</td><td>0</td><td>0</td><td>0</td></tr> <tr><td>GROUP INTERNAL AUDIT</td><td>0</td><td>0</td><td>0</td><td>0</td><td>0</td><td>0</td><td>0</td><td>0</td><td>0</td><td>0</td><td>0</td><td>0</td></tr> <tr><td>GROUP CHIEF STRATEGY OFFICE</td><td>0</td><td>0</td><td>0</td><td>0</td><td>0</td><td>0</td><td>0</td><td>0</td><td>0</td><td>0</td><td>0</td><td>0</td></tr> <tr><td>GROUP CHIEF FINANCE OFFICE</td><td>0</td><td>0</td><td>0</td><td>0</td><td>0</td><td>0</td><td>0</td><td>0</td><td>0</td><td>0</td><td>0</td><td>0</td></tr> <tr><td>GROUP CHIEF PEOPLE & CULTURE OFFICE</td><td>0</td><td>0</td><td>0</td><td>0</td><td>0</td><td>0</td><td>0</td><td>0</td><td>0</td><td>0</td><td>0</td><td>0</td></tr> <tr><td>PERFORMANCE, REWARDS & PLANNING SECTION</td><td>0</td><td>0</td><td>0</td><td>0</td><td>0</td><td>0</td><td>0</td><td>0</td><td>0</td><td>0</td><td>0</td><td>0</td></tr> <tr><td>TALENT DEVELOPMENT & LEADERSHIP SECTION</td><td>0</td><td>0</td><td>0</td><td>0</td><td>0</td><td>0</td><td>0</td><td>0</td><td>0</td><td>0</td><td>0</td><td>0</td></tr> <tr><td>ENGAGEMENT, CULTURE & INDUSTRIAL RELATIONS SECTION</td><td>0</td><td>0</td><td>0</td><td>0</td><td>0</td><td>0</td><td>0</td><td>0</td><td>0</td><td>0</td><td>0</td><td>0</td></tr> <tr><td>GROUP CHIEF FUTURE OFFICE</td><td>0</td><td>0</td><td>0</td><td>0</td><td>0</td><td>0</td><td>0</td><td>0</td><td>0</td><td>0</td><td>0</td><td>0</td></tr> <tr><td>APPLICATION SYSTEM DEVELOPMENT SECTION</td><td>118</td><td>0</td><td>0</td><td>0</td><td>0</td><td>0</td><td>0</td><td>0</td><td>0</td><td>0</td><td>0</td><td>0</td></tr> </tbody> </table> <p style="text-align: center; margin-top: 5px;"> 1 2 3 4 5 6 7 8 9 10 ... </p> <p>Filter ISS list.</p> <ul style="list-style-type: none"> To filter by year of application, select necessary year from the “Year” drop down. <div style="margin-top: 5px;"> Year: <input type="text" value="2023"/> </div> To filter by SBU/SUB of application, select necessary SBU/SUB from the “SBU/SUB”. <div style="margin-top: 5px;"> SBU/SUB: <input type="text" value="All"/> </div> <ul style="list-style-type: none"> To filter by TC/IC of application, select necessary TC/IC from the “TC/IC”. <div style="margin-top: 5px;"> TC/IC: <input type="text" value="All"/> </div>	TC/IC	January	February	March	April	May	June	July	August	September	October	November	December	PRESIDENT AND GROUP CHIEF EXECUTIVE	0	0	0	0	0	0	0	0	0	0	0	0	GROUP INTERNAL AUDIT	0	0	0	0	0	0	0	0	0	0	0	0	GROUP CHIEF STRATEGY OFFICE	0	0	0	0	0	0	0	0	0	0	0	0	GROUP CHIEF FINANCE OFFICE	0	0	0	0	0	0	0	0	0	0	0	0	GROUP CHIEF PEOPLE & CULTURE OFFICE	0	0	0	0	0	0	0	0	0	0	0	0	PERFORMANCE, REWARDS & PLANNING SECTION	0	0	0	0	0	0	0	0	0	0	0	0	TALENT DEVELOPMENT & LEADERSHIP SECTION	0	0	0	0	0	0	0	0	0	0	0	0	ENGAGEMENT, CULTURE & INDUSTRIAL RELATIONS SECTION	0	0	0	0	0	0	0	0	0	0	0	0	GROUP CHIEF FUTURE OFFICE	0	0	0	0	0	0	0	0	0	0	0	0	APPLICATION SYSTEM DEVELOPMENT SECTION	118	0	0	0	0	0	0	0	0	0	0	0
TC/IC	January	February	March	April	May	June	July	August	September	October	November	December																																																																																																																																				
PRESIDENT AND GROUP CHIEF EXECUTIVE	0	0	0	0	0	0	0	0	0	0	0	0																																																																																																																																				
GROUP INTERNAL AUDIT	0	0	0	0	0	0	0	0	0	0	0	0																																																																																																																																				
GROUP CHIEF STRATEGY OFFICE	0	0	0	0	0	0	0	0	0	0	0	0																																																																																																																																				
GROUP CHIEF FINANCE OFFICE	0	0	0	0	0	0	0	0	0	0	0	0																																																																																																																																				
GROUP CHIEF PEOPLE & CULTURE OFFICE	0	0	0	0	0	0	0	0	0	0	0	0																																																																																																																																				
PERFORMANCE, REWARDS & PLANNING SECTION	0	0	0	0	0	0	0	0	0	0	0	0																																																																																																																																				
TALENT DEVELOPMENT & LEADERSHIP SECTION	0	0	0	0	0	0	0	0	0	0	0	0																																																																																																																																				
ENGAGEMENT, CULTURE & INDUSTRIAL RELATIONS SECTION	0	0	0	0	0	0	0	0	0	0	0	0																																																																																																																																				
GROUP CHIEF FUTURE OFFICE	0	0	0	0	0	0	0	0	0	0	0	0																																																																																																																																				
APPLICATION SYSTEM DEVELOPMENT SECTION	118	0	0	0	0	0	0	0	0	0	0	0																																																																																																																																				

--End of Document --



myISS

User Guide For HOD



LOGIN AND DASHBOARD MODULE

10 Login & Logout myISS

To access the myISS, users should employ a modern web browser and enter the following *Uniform Resource Locator* (URL):

<https://myiss.sirim.my>.

This will lead users to the Login Page, depicted in Figure 1.

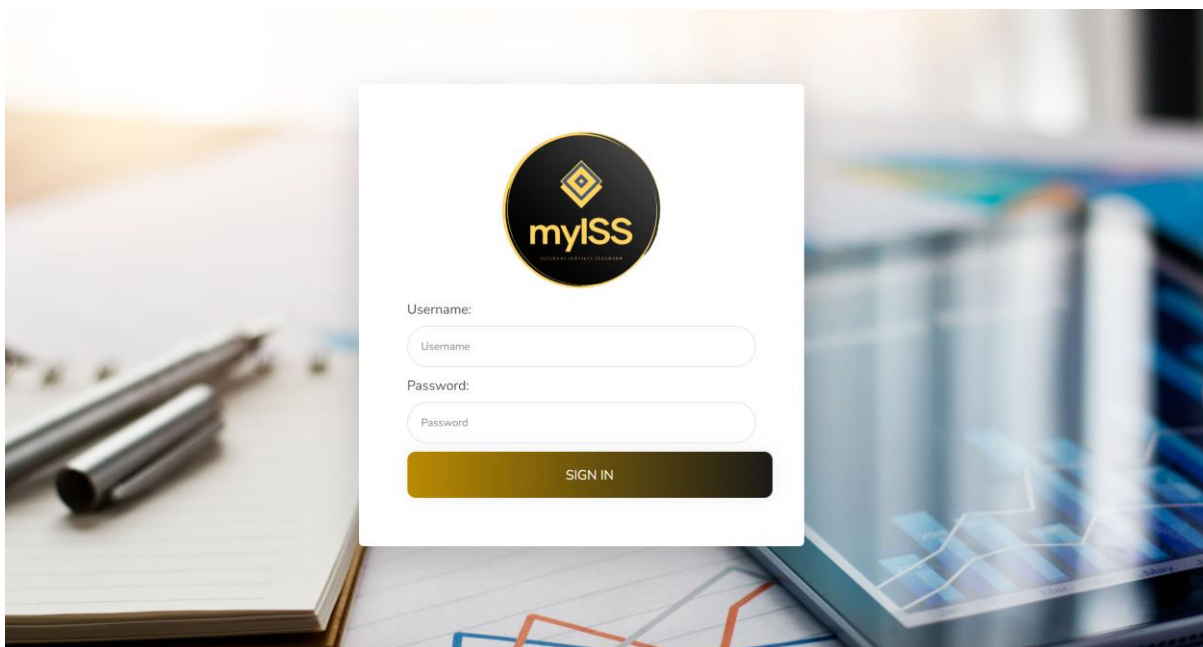

Figure 1: myISS Login Page

1. Key-in both username and password in the specified fields respectively.
**Note: Please verify that both inputs are accurate (be mindful of the Caps Lock).
2. Click the **SIGN IN** button. System will redirect users to the landing page which displays the dashboard as shown in Figure 2.

User's profile & login name

Left navigation menu

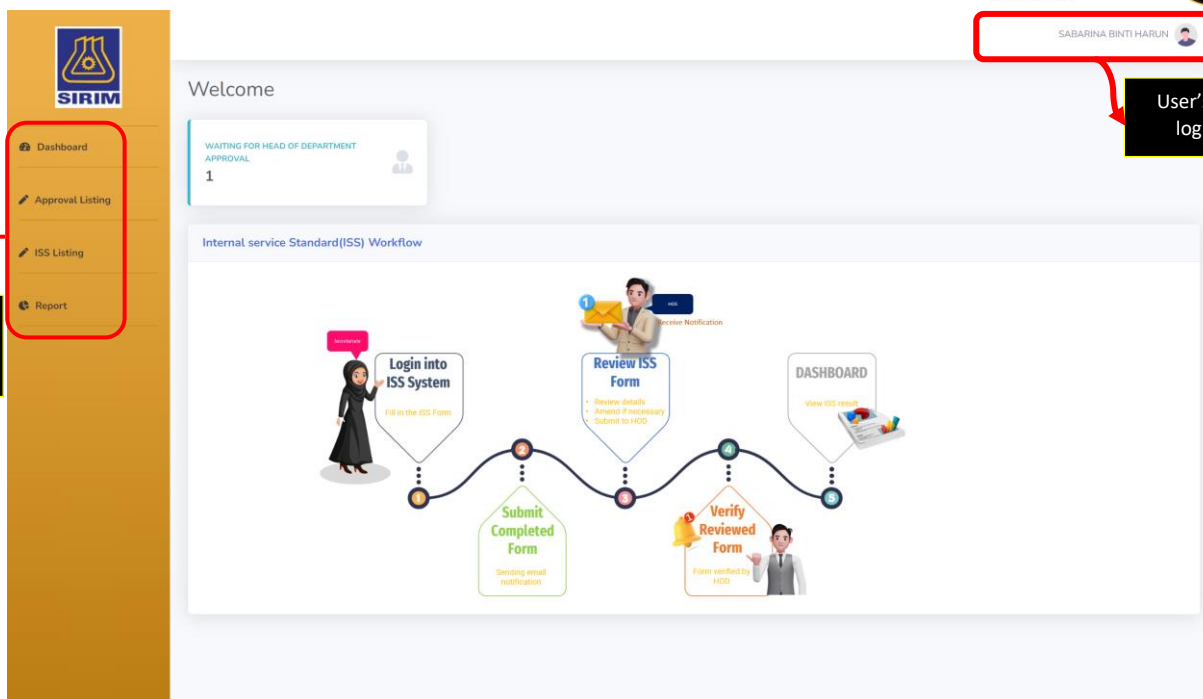







Figure 2: myISS Main Page Dashboard

NO	DESCRIPTION	FUNCTION
1	Left Navigation	Menu navigator
1.1	 Dashboard	Link to Dashboard page (home/landing page). <i>**Note: SIRIM Logo is also set to return to Dashboard page as home/landing page.</i>
1.2	 Approval Listing	Link to approve myISS.
1.3	 ISS Listing	Link to view myISS.
1.4	 Report	Link to report module.
2	Dashboard	Summary of activity.
2.1		Displays number of "WAITING FOR HEAD OF DEPARTMENT APPROVAL" where the ISS is to be reviewed and approved by HOD.

3. Your profile icon:

- On the top right of the screen click on the profile icon.

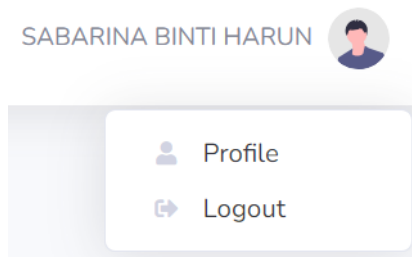

Figure 3: myISS profile and logout menu

3.1 Manage your profile.

3.1.1 Click on the “**Profile**” option.

3.1.2 The following profile form will be displayed as shown in Figure 4.

My Profile

Name:
SABARINA BINTI HARUN

Email:
sabarinah@sirim.my

Section:
GROUP CHIEF OPERATING OFFICE
GROUP OPERATIONS

Superior:
DATO' INDERA DR. AHMAD SABIRIN BIN ARSHAD, FASc

Figure 4: User Profile for reference.

3.2 Logout

3.2.1 Click on the “**Logout**” option.

3.2.2 The system will log you out and return to the login screen.



APPROVE ISS

MODULE

11. Approve ISS





The purpose of this module is to approve a new ISS for a particular month. This module will enable users:

- To approve or reject a new ISS for selected month in particular year.

STEP 1	<p>In the left navigation menu, click the “Approval Listing” icon.</p> <div style="text-align: center;">  </div>																																																																	
STEP 2	<p>Approve a new ISS creation</p> <ul style="list-style-type: none"> The approval listing will be displayed as shown below. <div style="border: 1px solid #ccc; padding: 5px; margin-bottom: 10px;"> <p><small>List of Waiting Approval</small></p> <table border="1" style="width: 100%; border-collapse: collapse;"> <thead> <tr> <th></th> <th>Reference No</th> <th>Month</th> <th>Year</th> <th>Company</th> <th>Department</th> <th>Status</th> <th>Requestor Name</th> </tr> </thead> <tbody> <tr> <td>Select</td> <td>MY0586022042</td> <td>March</td> <td>2023</td> <td>GROUP DIGITAL</td> <td>APPLICATION SYSTEM DEVELOPMENT SECTION</td> <td>AWAITING HOD APPROVAL</td> <td>NOR AMALINA BINTI MOHAMED FADZILAH</td> </tr> </tbody> </table> </div> <ul style="list-style-type: none"> Click “Select” link to view the ISS in detail. <div style="border: 1px solid #ccc; padding: 5px; margin-bottom: 10px;"> <table border="1" style="width: 100%; border-collapse: collapse;"> <thead> <tr> <th></th> <th>Reference No</th> <th>Month</th> <th>Year</th> <th>Company</th> <th>Department</th> <th>Status</th> <th>Requestor Name</th> </tr> </thead> <tbody> <tr> <td>Select</td> <td>MY0586022042</td> <td>March</td> <td>2023</td> <td>GROUP DIGITAL</td> <td>APPLICATION SYSTEM DEVELOPMENT SECTION</td> <td>AWAITING HOD APPROVAL</td> <td>NOR AMALINA BINTI MOHAMED FADZILAH</td> </tr> </tbody> </table> </div> <ul style="list-style-type: none"> The following details will be displayed: <div style="border: 1px solid #ccc; padding: 5px; margin-bottom: 10px;"> <p><small>List of Internal Service Standard</small></p> <p>Month: March Year: 2023</p> <p>SBU/SUB: GROUP DIGITAL TC/IC: APPLICATION SYSTEM DEVELOPMENT SECTION</p> <p>Status: AWAITING HOD APPROVAL</p> <table border="1" style="width: 100%; border-collapse: collapse;"> <thead> <tr> <th>No</th> <th>Core Process/Activity</th> <th>Service Standard</th> <th>Quantity(Completed)</th> <th>Achievement(Meet ISS)</th> <th>% Achievement</th> <th>Justification(for non-compliance)</th> <th>Service Details of Corrective Actions Standard</th> <th>Planned Date</th> <th>Completion Date</th> <th>Remarks</th> </tr> </thead> <tbody> <tr> <td>1</td> <td>core 1</td> <td>3 working days</td> <td>5</td> <td>5</td> <td>100</td> <td></td> <td></td> <td></td> <td></td> <td></td> </tr> <tr> <td colspan="4"></td> <td style="text-align: center;">Average</td> <td>100</td> <td></td> <td></td> <td></td> <td></td> <td></td> </tr> </tbody> </table> <p>Prepared by: Name: NOR AMALINA BINTI MOHAMED FADZILAH Designation: GROUP OPERATIONS Date: 23 October 2023</p> <div style="text-align: right;"> Accept Reject Close </div> </div> <ul style="list-style-type: none"> Upon approval completion, click “Accept” button to approve and fill in the message box. Click “Yes” button to proceed approval. Click “Reject” button to reject and fill in the message box. Click “Yes” button to proceed. PIC will receive a notification if the ISS is approved by HOD. The following email will be displayed: 		Reference No	Month	Year	Company	Department	Status	Requestor Name	Select	MY0586022042	March	2023	GROUP DIGITAL	APPLICATION SYSTEM DEVELOPMENT SECTION	AWAITING HOD APPROVAL	NOR AMALINA BINTI MOHAMED FADZILAH		Reference No	Month	Year	Company	Department	Status	Requestor Name	Select	MY0586022042	March	2023	GROUP DIGITAL	APPLICATION SYSTEM DEVELOPMENT SECTION	AWAITING HOD APPROVAL	NOR AMALINA BINTI MOHAMED FADZILAH	No	Core Process/Activity	Service Standard	Quantity(Completed)	Achievement(Meet ISS)	% Achievement	Justification(for non-compliance)	Service Details of Corrective Actions Standard	Planned Date	Completion Date	Remarks	1	core 1	3 working days	5	5	100										Average	100					
	Reference No	Month	Year	Company	Department	Status	Requestor Name																																																											
Select	MY0586022042	March	2023	GROUP DIGITAL	APPLICATION SYSTEM DEVELOPMENT SECTION	AWAITING HOD APPROVAL	NOR AMALINA BINTI MOHAMED FADZILAH																																																											
	Reference No	Month	Year	Company	Department	Status	Requestor Name																																																											
Select	MY0586022042	March	2023	GROUP DIGITAL	APPLICATION SYSTEM DEVELOPMENT SECTION	AWAITING HOD APPROVAL	NOR AMALINA BINTI MOHAMED FADZILAH																																																											
No	Core Process/Activity	Service Standard	Quantity(Completed)	Achievement(Meet ISS)	% Achievement	Justification(for non-compliance)	Service Details of Corrective Actions Standard	Planned Date	Completion Date	Remarks																																																								
1	core 1	3 working days	5	5	100																																																													
				Average	100																																																													

SIRIM ISS: Status Notification

 sirimapps@sirim.my
To: NOR AMALINA BINTI MOHAMED FADZILAH

 Reply  Reply All  Forward  Sun 7/1/2024 11:10 AM

SIRIM ISS - Approval Notification

Dear Sir/Madam NOR AMALINA BINTI MOHAMED FADZILAH,

This is to inform that your Internal Service Standard in SIRIM ISS has been completed and approved.

SIRIM ISS Reference number: MY0586022042
SIRIM ISS Creator Name: NOR AMALINA BINTI MOHAMED FADZILAH
Month/Year: March 2023
SBU/SUB: GROUP DIGITAL
TC/C: APPLICATION SYSTEM DEVELOPMENT SECTION

Please login [here](#) to review.

Thank you.

- PIC will receive a notification if the ISS is rejected by HOS. The following email will be displayed:

SIRIM ISS: Status Notification

 sirimapps@sirim.my
To: NOR AMALINA BINTI MOHAMED FADZILAH

 Reply  Reply All  Forward  Sat 6/1/2024 6:30 PM

SIRIM ISS - Approval Notification

Dear Sir/Madam NOR AMALINA BINTI MOHAMED FADZILAH,

This is to inform that your Internal Service Standard (ISS) available in SIRIM ISS has been rejected.

SIRIM ISS Reference number: MY0586022042
SIRIM ISS Creator Name: NOR AMALINA BINTI MOHAMED FADZILAH
Month/Year: March 2023
SBU/SUB: GROUP DIGITAL
TC/C: APPLICATION SYSTEM DEVELOPMENT SECTION
Reason: this is testing

Please login [here](#) to review.

Thank you.

View submission status

- On the left navigation, click Dashboard menu.
- Note that your dashboard displays a new total of “WAITING FOR HEAD OF DEPARTMENT APPROVAL”.

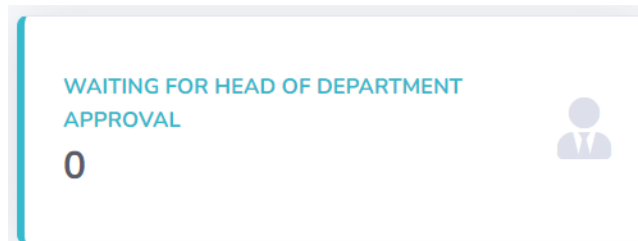



ISS LISTING MODULE

12. ISS Listing

The purpose of this module is to view the ISS that has been applied by PIC.
 This module will enable users:

1. To view all ISS applied with status respectively.
2. To track progress of ISS that has been applied.

STEP 1	In the left navigation menu, click the “ISS Listing” menu. <div style="text-align: center; margin-top: 10px;">  </div>																																																																														
STEP 2	<p>List of ISS.</p> <ul style="list-style-type: none"> The system will display all ISS that has been applied details as below: <div style="border: 1px solid #ccc; padding: 5px; margin-bottom: 10px;"> <p style="font-size: small; color: #4a7ebb;">List of ISS</p> <table border="1" style="width: 100%; border-collapse: collapse; font-size: x-small;"> <thead> <tr style="background-color: #333; color: white;"> <th></th> <th>Reference No</th> <th>Applicant Name</th> <th>Company</th> <th>Department</th> <th>Month</th> <th>Year</th> <th>Average % Achievement</th> <th>Status</th> </tr> </thead> <tbody> <tr> <td style="text-align: center;">Select</td> <td>MY0547607653</td> <td>NOR AMALINA BINTI MOHAMED FADZILAH</td> <td>GROUP DIGITAL</td> <td>APPLICATION SYSTEM DEVELOPMENT SECTION</td> <td>January</td> <td>2023</td> <td>118</td> <td>APPROVED</td> </tr> <tr> <td style="text-align: center;">Select</td> <td>MY0586022042</td> <td>NOR AMALINA BINTI MOHAMED FADZILAH</td> <td>GROUP DIGITAL</td> <td>APPLICATION SYSTEM DEVELOPMENT SECTION</td> <td>March</td> <td>2023</td> <td>100</td> <td>APPROVED</td> </tr> </tbody> </table> </div> <p>View iss in detail.</p> <ul style="list-style-type: none"> Click “Select” button for the selected ISS. <div style="border: 1px solid #ccc; padding: 5px; margin-bottom: 10px;"> <table border="1" style="width: 100%; border-collapse: collapse; font-size: x-small;"> <thead> <tr style="background-color: #333; color: white;"> <th></th> <th>Reference No</th> <th>Applicant Name</th> <th>Company</th> <th>Department</th> <th>Month</th> <th>Year</th> <th>Average % Achievement</th> <th>Status</th> </tr> </thead> <tbody> <tr> <td style="text-align: center;">Select</td> <td>MY0547607653</td> <td>NOR AMALINA BINTI MOHAMED FADZILAH</td> <td>GROUP DIGITAL</td> <td>APPLICATION SYSTEM DEVELOPMENT SECTION</td> <td>January</td> <td>2023</td> <td>118</td> <td>APPROVED</td> </tr> </tbody> </table> </div> <ul style="list-style-type: none"> The following details will be displayed as below: <div style="border: 1px solid #ccc; padding: 5px; margin-bottom: 10px;"> <p style="font-size: x-small; color: #4a7ebb;">List of Internal Service Standard</p> <p style="font-size: x-small;">Month: March Year: 2023</p> <p style="font-size: x-small;">SBU/SUB: GROUP DIGITAL TC/C: APPLICATION SYSTEM DEVELOPMENT SECTION</p> <p style="font-size: x-small;">Status: APPROVED</p> <table border="1" style="width: 100%; border-collapse: collapse; font-size: x-small;"> <thead> <tr style="background-color: #333; color: white;"> <th>No</th> <th>Core Process/Activity</th> <th>Service Standard</th> <th>Quantity(Completed)</th> <th>Achievement(Meet ISS)</th> <th>% Achievement</th> <th>Justification(for non-compliance)</th> <th>Service Details of Corrective Actions Standard</th> <th>Planned Date</th> <th>Completion Date</th> <th>Remarks</th> </tr> </thead> <tbody> <tr> <td style="text-align: center;">1</td> <td>core 1</td> <td>3 working days</td> <td style="text-align: center;">5</td> <td style="text-align: center;">5</td> <td style="text-align: center;">100</td> <td></td> <td></td> <td></td> <td></td> <td></td> </tr> <tr> <td></td> <td></td> <td></td> <td></td> <td style="text-align: center;">Average</td> <td style="text-align: center;">100</td> <td></td> <td></td> <td></td> <td></td> <td></td> </tr> </tbody> </table> <p style="font-size: x-small; margin-top: 5px;">Prepared by: Name: NOR AMALINA BINTI MOHAMED FADZILAH Designation: GROUP OPERATIONS Date: 02 November 2023 Close</p> </div> <ul style="list-style-type: none"> Click “Close” button to go back to the ISS Listing page. 		Reference No	Applicant Name	Company	Department	Month	Year	Average % Achievement	Status	Select	MY0547607653	NOR AMALINA BINTI MOHAMED FADZILAH	GROUP DIGITAL	APPLICATION SYSTEM DEVELOPMENT SECTION	January	2023	118	APPROVED	Select	MY0586022042	NOR AMALINA BINTI MOHAMED FADZILAH	GROUP DIGITAL	APPLICATION SYSTEM DEVELOPMENT SECTION	March	2023	100	APPROVED		Reference No	Applicant Name	Company	Department	Month	Year	Average % Achievement	Status	Select	MY0547607653	NOR AMALINA BINTI MOHAMED FADZILAH	GROUP DIGITAL	APPLICATION SYSTEM DEVELOPMENT SECTION	January	2023	118	APPROVED	No	Core Process/Activity	Service Standard	Quantity(Completed)	Achievement(Meet ISS)	% Achievement	Justification(for non-compliance)	Service Details of Corrective Actions Standard	Planned Date	Completion Date	Remarks	1	core 1	3 working days	5	5	100										Average	100					
	Reference No	Applicant Name	Company	Department	Month	Year	Average % Achievement	Status																																																																							
Select	MY0547607653	NOR AMALINA BINTI MOHAMED FADZILAH	GROUP DIGITAL	APPLICATION SYSTEM DEVELOPMENT SECTION	January	2023	118	APPROVED																																																																							
Select	MY0586022042	NOR AMALINA BINTI MOHAMED FADZILAH	GROUP DIGITAL	APPLICATION SYSTEM DEVELOPMENT SECTION	March	2023	100	APPROVED																																																																							
	Reference No	Applicant Name	Company	Department	Month	Year	Average % Achievement	Status																																																																							
Select	MY0547607653	NOR AMALINA BINTI MOHAMED FADZILAH	GROUP DIGITAL	APPLICATION SYSTEM DEVELOPMENT SECTION	January	2023	118	APPROVED																																																																							
No	Core Process/Activity	Service Standard	Quantity(Completed)	Achievement(Meet ISS)	% Achievement	Justification(for non-compliance)	Service Details of Corrective Actions Standard	Planned Date	Completion Date	Remarks																																																																					
1	core 1	3 working days	5	5	100																																																																										
				Average	100																																																																										

4

REPORT MODULE

13. Report

The purpose of this module is to enable users to view the report of their ISS application in the whole year.

STEP 1	In the left navigation menu, click the “Report” menu. <div style="text-align: center; margin-top: 10px;">  </div>																																																																																																																																															
STEP 2	<p>View report.</p> <ul style="list-style-type: none"> The system will list all the ISS applied by TC/IC in a year. <div style="border: 1px solid #ccc; padding: 5px; margin-bottom: 10px;"> <p><small>Reporting</small></p> <p>Filter:</p> <p>Year: <input type="text" value="2023"/></p> <p>SBU/SUB: <input type="text" value="All"/></p> <p>TC/IC: <input type="text" value="All"/></p> </div> <table border="1" style="width: 100%; border-collapse: collapse; text-align: center;"> <thead> <tr style="background-color: #333; color: white;"> <th>TC/IC</th> <th>January</th> <th>February</th> <th>March</th> <th>April</th> <th>May</th> <th>June</th> <th>July</th> <th>August</th> <th>September</th> <th>October</th> <th>November</th> <th>December</th> </tr> </thead> <tbody> <tr><td>PRESIDENT AND GROUP CHIEF EXECUTIVE</td><td>0</td><td>0</td><td>0</td><td>0</td><td>0</td><td>0</td><td>0</td><td>0</td><td>0</td><td>0</td><td>0</td><td>0</td></tr> <tr><td>GROUP INTERNAL AUDIT</td><td>0</td><td>0</td><td>0</td><td>0</td><td>0</td><td>0</td><td>0</td><td>0</td><td>0</td><td>0</td><td>0</td><td>0</td></tr> <tr><td>GROUP CHIEF STRATEGY OFFICE</td><td>0</td><td>0</td><td>0</td><td>0</td><td>0</td><td>0</td><td>0</td><td>0</td><td>0</td><td>0</td><td>0</td><td>0</td></tr> <tr><td>GROUP CHIEF FINANCE OFFICE</td><td>0</td><td>0</td><td>0</td><td>0</td><td>0</td><td>0</td><td>0</td><td>0</td><td>0</td><td>0</td><td>0</td><td>0</td></tr> <tr><td>GROUP CHIEF PEOPLE & CULTURE OFFICE</td><td>0</td><td>0</td><td>0</td><td>0</td><td>0</td><td>0</td><td>0</td><td>0</td><td>0</td><td>0</td><td>0</td><td>0</td></tr> <tr><td>PERFORMANCE, REWARDS & PLANNING SECTION</td><td>0</td><td>0</td><td>0</td><td>0</td><td>0</td><td>0</td><td>0</td><td>0</td><td>0</td><td>0</td><td>0</td><td>0</td></tr> <tr><td>TALENT DEVELOPMENT & LEADERSHIP SECTION</td><td>0</td><td>0</td><td>0</td><td>0</td><td>0</td><td>0</td><td>0</td><td>0</td><td>0</td><td>0</td><td>0</td><td>0</td></tr> <tr><td>ENGAGEMENT, CULTURE & INDUSTRIAL RELATIONS SECTION</td><td>0</td><td>0</td><td>0</td><td>0</td><td>0</td><td>0</td><td>0</td><td>0</td><td>0</td><td>0</td><td>0</td><td>0</td></tr> <tr><td>GROUP CHIEF FUTURE OFFICE</td><td>0</td><td>0</td><td>0</td><td>0</td><td>0</td><td>0</td><td>0</td><td>0</td><td>0</td><td>0</td><td>0</td><td>0</td></tr> <tr><td>APPLICATION SYSTEM DEVELOPMENT SECTION</td><td>118</td><td>0</td><td>0</td><td>0</td><td>0</td><td>0</td><td>0</td><td>0</td><td>0</td><td>0</td><td>0</td><td>0</td></tr> </tbody> </table> <p style="text-align: center; margin-top: 5px;"> 1 2 3 4 5 6 7 8 9 10 ... </p> <p>Filter ISS list.</p> <ul style="list-style-type: none"> To filter by year of application, select necessary year from the “Year” drop down. <div style="margin-top: 5px;"> Year: <input type="text" value="2023"/> </div> To filter by SBU/SUB of application, select necessary SBU/SUB from the “SBU/SUB”. <div style="margin-top: 5px;"> SBU/SUB: <input type="text" value="All"/> </div> To filter by TC/IC of application, select necessary TC/IC from the “TC/IC”. <div style="margin-top: 5px;"> TC/IC: <input type="text" value="All"/> </div> 	TC/IC	January	February	March	April	May	June	July	August	September	October	November	December	PRESIDENT AND GROUP CHIEF EXECUTIVE	0	0	0	0	0	0	0	0	0	0	0	0	GROUP INTERNAL AUDIT	0	0	0	0	0	0	0	0	0	0	0	0	GROUP CHIEF STRATEGY OFFICE	0	0	0	0	0	0	0	0	0	0	0	0	GROUP CHIEF FINANCE OFFICE	0	0	0	0	0	0	0	0	0	0	0	0	GROUP CHIEF PEOPLE & CULTURE OFFICE	0	0	0	0	0	0	0	0	0	0	0	0	PERFORMANCE, REWARDS & PLANNING SECTION	0	0	0	0	0	0	0	0	0	0	0	0	TALENT DEVELOPMENT & LEADERSHIP SECTION	0	0	0	0	0	0	0	0	0	0	0	0	ENGAGEMENT, CULTURE & INDUSTRIAL RELATIONS SECTION	0	0	0	0	0	0	0	0	0	0	0	0	GROUP CHIEF FUTURE OFFICE	0	0	0	0	0	0	0	0	0	0	0	0	APPLICATION SYSTEM DEVELOPMENT SECTION	118	0	0	0	0	0	0	0	0	0	0	0
TC/IC	January	February	March	April	May	June	July	August	September	October	November	December																																																																																																																																				
PRESIDENT AND GROUP CHIEF EXECUTIVE	0	0	0	0	0	0	0	0	0	0	0	0																																																																																																																																				
GROUP INTERNAL AUDIT	0	0	0	0	0	0	0	0	0	0	0	0																																																																																																																																				
GROUP CHIEF STRATEGY OFFICE	0	0	0	0	0	0	0	0	0	0	0	0																																																																																																																																				
GROUP CHIEF FINANCE OFFICE	0	0	0	0	0	0	0	0	0	0	0	0																																																																																																																																				
GROUP CHIEF PEOPLE & CULTURE OFFICE	0	0	0	0	0	0	0	0	0	0	0	0																																																																																																																																				
PERFORMANCE, REWARDS & PLANNING SECTION	0	0	0	0	0	0	0	0	0	0	0	0																																																																																																																																				
TALENT DEVELOPMENT & LEADERSHIP SECTION	0	0	0	0	0	0	0	0	0	0	0	0																																																																																																																																				
ENGAGEMENT, CULTURE & INDUSTRIAL RELATIONS SECTION	0	0	0	0	0	0	0	0	0	0	0	0																																																																																																																																				
GROUP CHIEF FUTURE OFFICE	0	0	0	0	0	0	0	0	0	0	0	0																																																																																																																																				
APPLICATION SYSTEM DEVELOPMENT SECTION	118	0	0	0	0	0	0	0	0	0	0	0																																																																																																																																				

--End of Document --